

HIAB T-CLX 018



HIAB T-CLX 018 BASIC DATA

| Technical data CE/CEN | T-CLX 018-1 | T-CLX 018-2 | T-CLX 018-3 |
|---|---------------------|--------------------------------|---|
| Max. lifting capacity [kNm] | 19 | 18 | 19 |
| Lifting capacity [tm] | 1,88 | 1,84 | 1,86 |
| Outreach / lifting capacity, hydraulic extension (m / kg) | 1,1/1700 1,9/990 | 1,2/1540 2,0/920 3,0/610 | 1,3/1500 2,1/910 3,1/600 4,1/450 |
| Outreach / lifting capacity, manual extension (m / kg) | 4,2/440 | 4,2/430 | |
| Outreach, hydraulic extensions [m] | 2 | 3,1 | 4,2 |
| Hydraulic boom extensions [m] | 0,9 | 1,9 | 2,9 |
| Outreach, manual extensions [m] | 4,2 | 4,2 | |
| Lifting height above installation level [m] | 3,2 | 4,3 | 5,3 |
| Manual Lifting height above installation level inc. Manual ext.[m] | 5,3 | 5,3 | |
| Recommended oil flow Lo [l/min] | 5 | 5 | 5 |
| Power needed at rec. oil flow [kW] | 1,5 | 1,5 | 1,5 |
| Max. working pressure [MPa] | 18,5 | 18,5 | 18,5 |
| Tank Capacity PTO [l] | 18 | 18 | 18 |
| Slewing angle [°] | 330 | 330 | 330 |
| Max. slope viable at full capacity [°] | 7,5 | 7,4 | 7 |
| Slewing torque, gross [kNm] | 3 | 3 | 3 |
| Slewing speed [°/s] | 14 | 14 | 14 |
| Height in folded position [mm] | 1423 | 1423 | 1423 |
| Width in folded position static mounted [mm] | 818 | 818 | 818 |
| Width in folded position truck mounted beam/with stab beam and tilting [mm] | 1650/1894 | 1650/1894 | 1650/1894 |
| Installation space needed static mounted [mm] | 317 | 317 | 317 |
| Installation space needed truck mounted [mm] | 426 | 426 | 426 |
| Weight, static mounted [kg] | 180 | 210 | 240 |
| Weight, mounting frame plus 2 short hydr. stabiliser legs [kg] | 88 | 88 | 88 |

This table shows a few examples of models, and represents some of all options available. With the opportunity to configure your crane, we can provide you with a crane perfectly tailored to your needs.

Please contact your local dealer for more information on the variety of options we can offer.

HIAB T-CLX 018

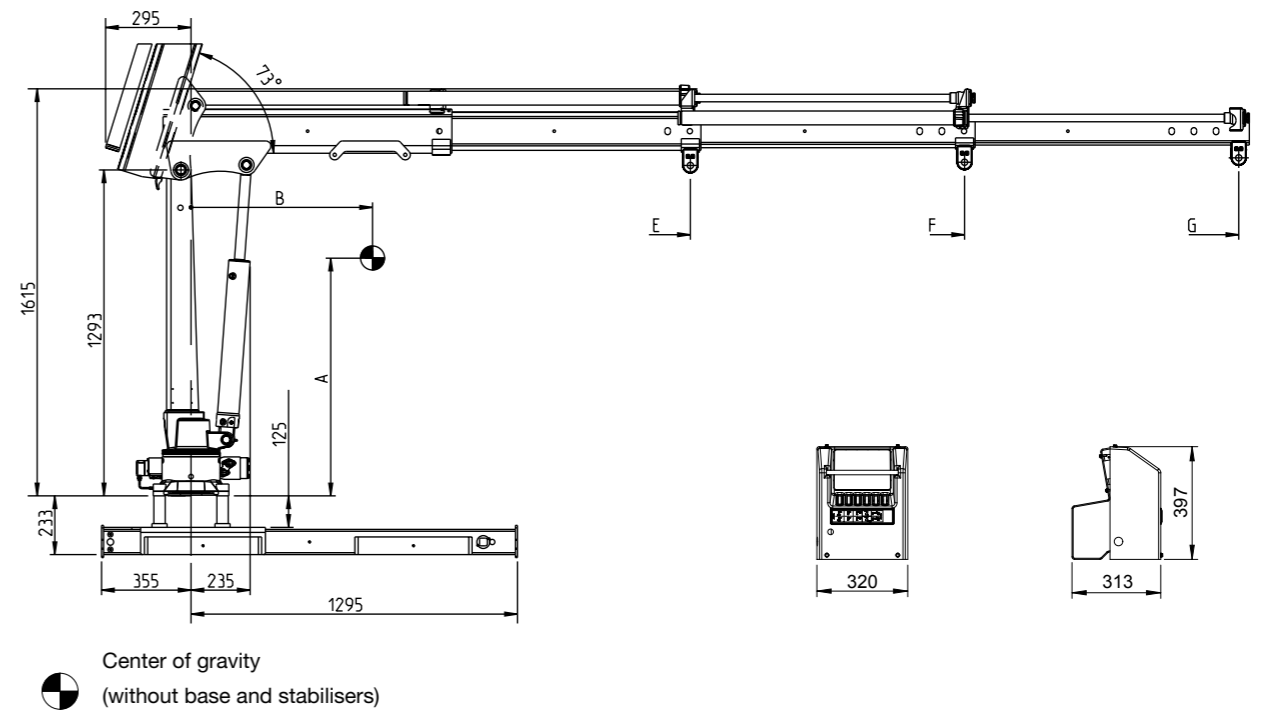

| | A | B | C | D | Emin. | Emax. | Fmin. | Fmax. | Gmin. | Gmax. | H |
|------------------|------|-----|-----|----|-------|-------|-------|-------|-------|-------|----|
| HIAB T-CLX 018-1 | 770 | 290 | 530 | 70 | 1075 | 1981 | N/A | N/A | N/A | N/A | 10 |
| HIAB T-CLX 018-2 | 930 | 570 | 560 | 60 | 1075 | 1981 | 1163 | 3069 | N/A | N/A | 10 |
| HIAB T-CLX 018-3 | 1050 | 880 | 570 | 50 | 1075 | 1981 | 1163 | 3069 | 1250 | 4157 | 10 |

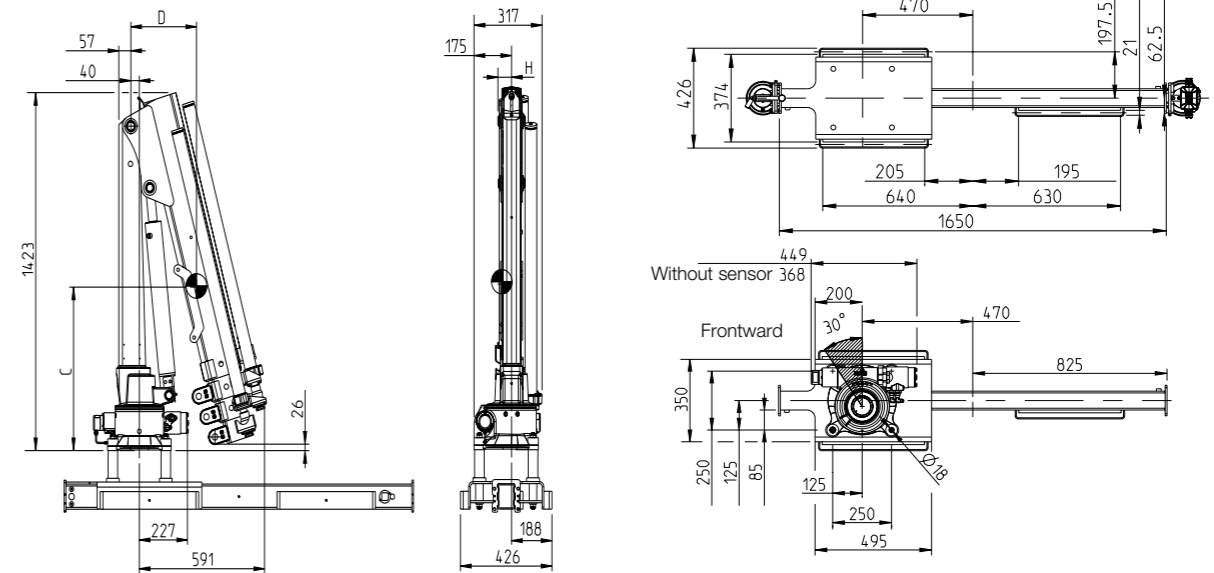

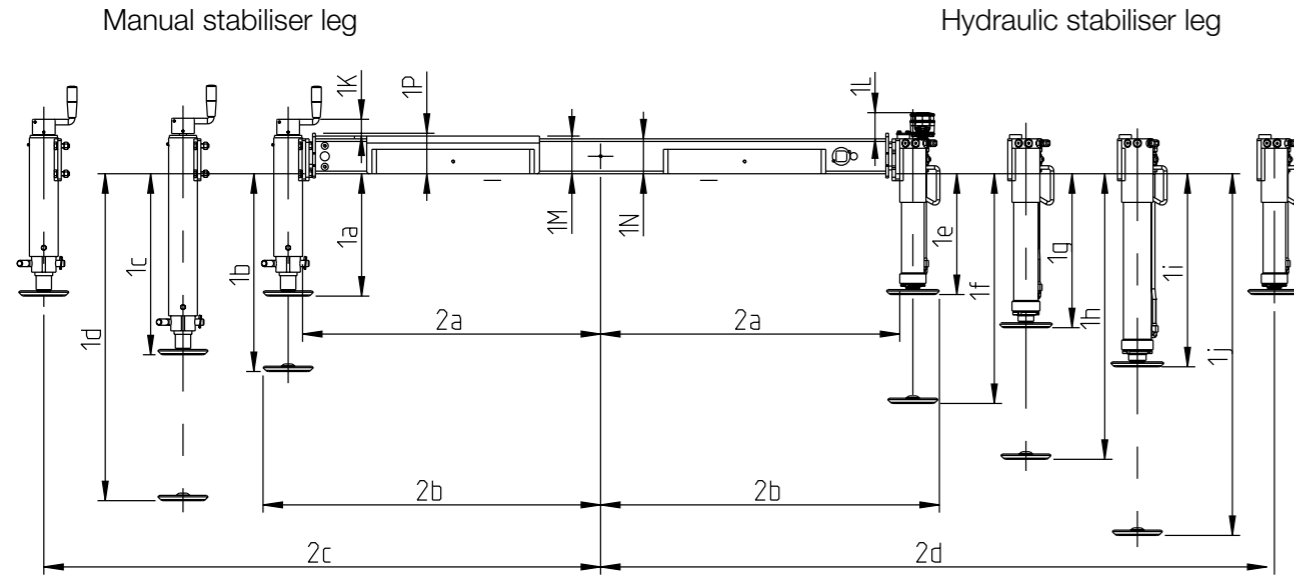

Base with tiltable stabiliser legs

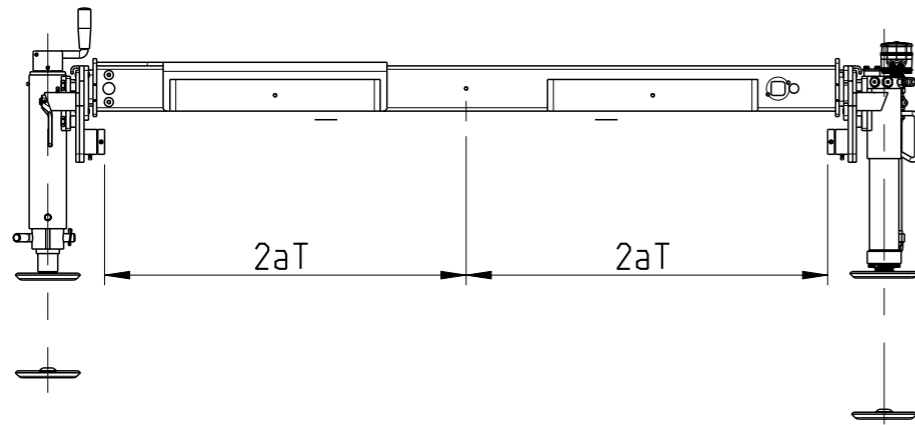

Tiltable stabiliser leg parking position

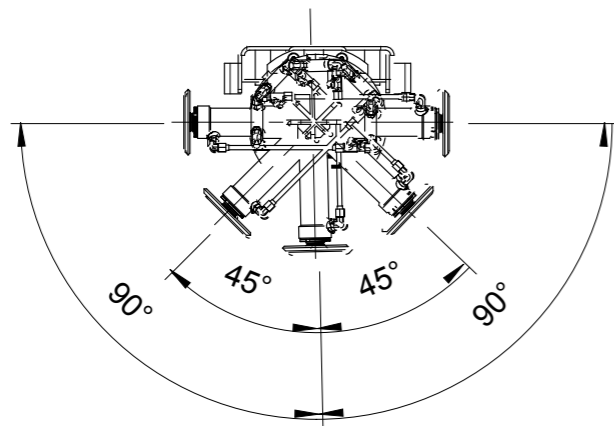

Other base dimensions

| | Fixed stabiliser leg position | Tiltable stabiliser leg |
|----|-------------------------------|-------------------------|
| 1K | 56 | 33 |
| 1L | 75 | 52 |
| 1M | 108 | |
| 1N | 100 | |
| 1P | 116 | |

| | | Stabiliser leg length | | |
|--------------------------|--------|-----------------------|------|-------------------------|
| | | Fixed stabiliser leg | | Tiltable stabiliser leg |
| Manual stabiliser leg | Short | 1a | 351 | 374 |
| | | 1b | 567 | 590 |
| | Medium | 1c | 519 | 542 |
| | | 1d | 937 | 960 |
| Hydraulic stabiliser leg | Short | 1e | 346 | 369 |
| | | 1f | 658 | 681 |
| | Medium | 1g | 441 | 464 |
| | | 1h | 818 | 841 |
| | Long | 1i | 553 | 576 |
| | | 1j | 1036 | 1059 |

| | | Base width | | |
|-------------------------------|-----|----------------------|---------------------------------------|--|
| Mechanical Stabiliser leg | | Fixed stabiliser leg | Stabiliser beam length Short (300 mm) | Stabiliser beam length Medium (800 mm) |
| Fixed stabiliser leg position | 2a | 834 | 854 | |
| | 2b | 947 | 967 | |
| | 2c | 875 | 1195 | 1695 |
| | 2d | | 1195 | - |
| Tiltable stabiliser leg | 2aT | 780 | 800 | |
| | 2b | 977 | 997 | |
| | 2c | 905 | 1225 | 1725 |
| | 2d | | 1225 | - |

| | | Base width | | |
|-------------------------------|-----|----------------------|---------------------------------------|--|
| Hydraulic Stabiliser leg | | Fixed stabiliser leg | Stabiliser beam length Short (300 mm) | Stabiliser beam length Medium (800 mm) |
| Fixed stabiliser leg position | 2a | 837 | 857 | |
| | 2b | 950 | 970 | |
| | 2c | 875 | 1195 | 1695 |
| | 2d | | 1195 | - |
| Tiltable stabiliser leg | 2aT | 780 | 800 | |
| | 2b | 981 | 1001 | |
| | 2c | 895 | 1225 | 1725 |
| | 2d | | 1225 | - |

BUILT TO PERFORM

Hiab is the world's leading provider of on-road load handling equipment. Customer satisfaction is the first priority for us. Hiab's product range includes HIAB loader cranes, JONSERED recycling and forestry cranes, LOGLIFT forestry cranes, MOFFETT truck mounted forklifts and MULTILIFT demountables, as well as DEL, WALTCO and ZEPRO tail lifts.

hiab.com

Hiab is part of Cargotec.

cargotec.com



© BD-TCLX018-EN-WW_160314



hiab.com