

HIAB T-DUO 038



HIAB T-DUO 038 BASIC DATA

Technical data	DUO 038-2	DUO 038-3	DUO 038-4
Max. lifting capacity (kNm)	34,8	34,5	34,2
Lifting capacity (tm)	3,5	3,5	3,5
Outreach / lifting capacity, hydraulic extension (m/kg)	1.5/2360 2.5/1400 3.6/960	1.6/2200 2.6/1320 3.7/920 4.8/700	1.7/2040 2.7/1240 3.8/860 4.9/660 6.0/540
Outreach / lifting capacity, manual extension (m/kg)	4.8/720 6.0/520	6.0/540 7.2/290	7.2/350
Outreach, hydraulic extensions (m)	2,1	3,2	4,3
Hydraulic boom extensions (m)	3,6	4,8	6
Outreach, manual extensions (m)	2,4	2,4	1,2
Lifting height above installation level (m)	5,1	6,3	7,4
Recommended oil flow (l/min)	10	10	10
Power needed at rec. oil flow (kW)	3	3	3
Max. working pressure (MPa)	17,5	17,5	17,5
Tank Capacity PTO (l)	18	18	18
Slewing angle (°)	322	322	322
Max. slope viable at full capacity (°)	5	5	5
Slewing torque, gross (kNm)	3	3	3
Slewing speed (°/s)	10	10	10
Height in folded position (mm)	1702	1702	1702
Width in folded position static mounted (mm)	883	883	883
Width in folded position truck mounted (mm) no stab beam/with stab beam and tilting	1826/1926	1826/1926	1826/1926
Installation space needed static mounted (mm)	300	300	300
Installation space needed truck mounted (mm)	536	536	536
Weight, static mounted (kg)	290	330	370
weight, mounting frame plus 2 short hydr. stabilizer legs (kg)	126	126	126

This table shows a few examples of models, and represents some of all options available. With the opportunity to configure your crane, we can provide you with a crane perfectly tailored to your needs.

Please contact your local dealer for more information on the variety of options we can offer.

HIAB T-DUO 038-2

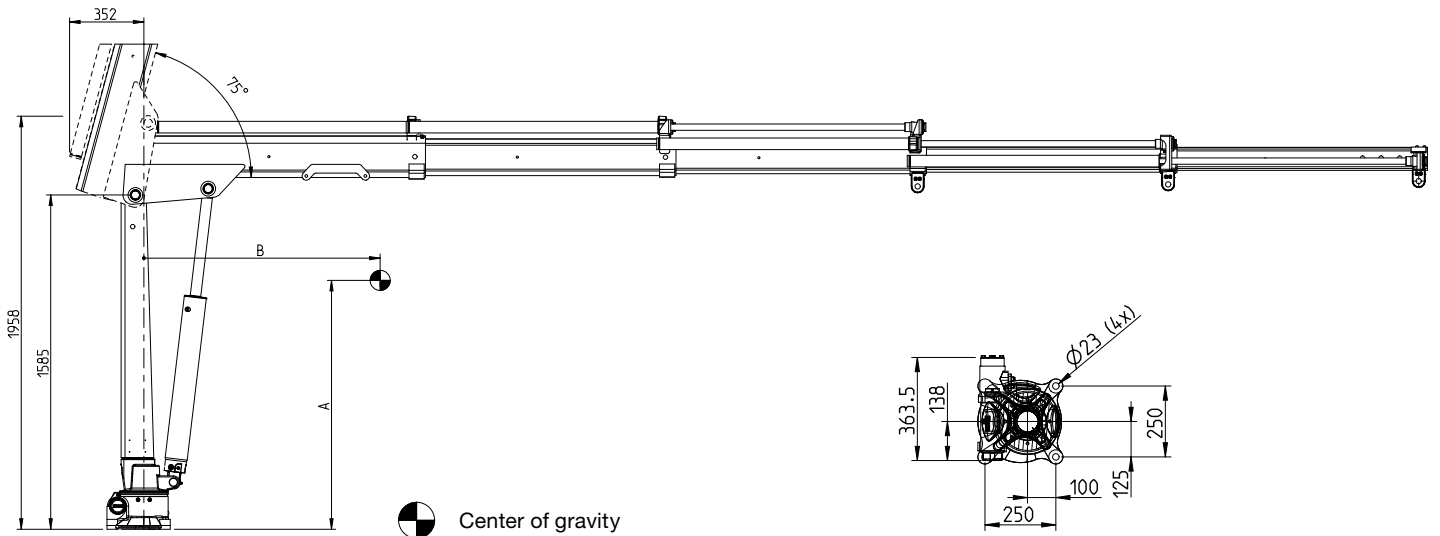

 Center of gravity

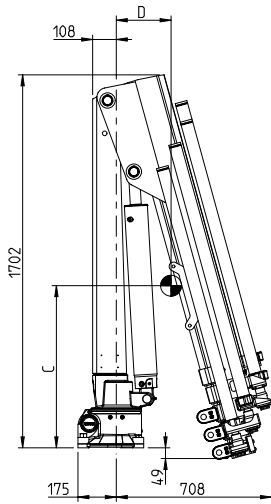

A	B	C	D
1090	730	730	200

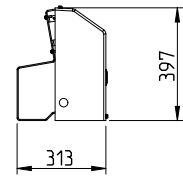
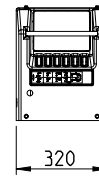

Capacity plate HIAB T-DUO 038-2

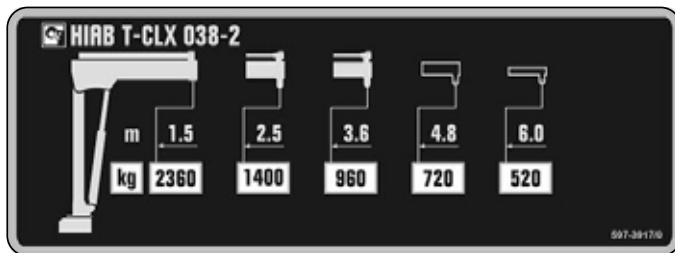

Load diagram HIAB T-DUO 038-2

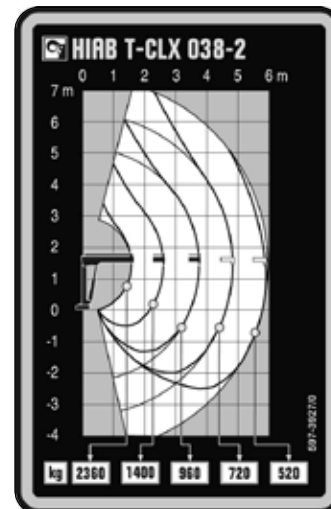

HIAB T-DUO 038-3

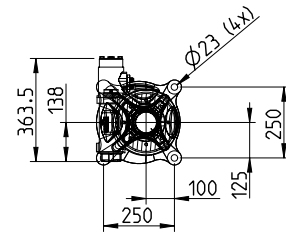
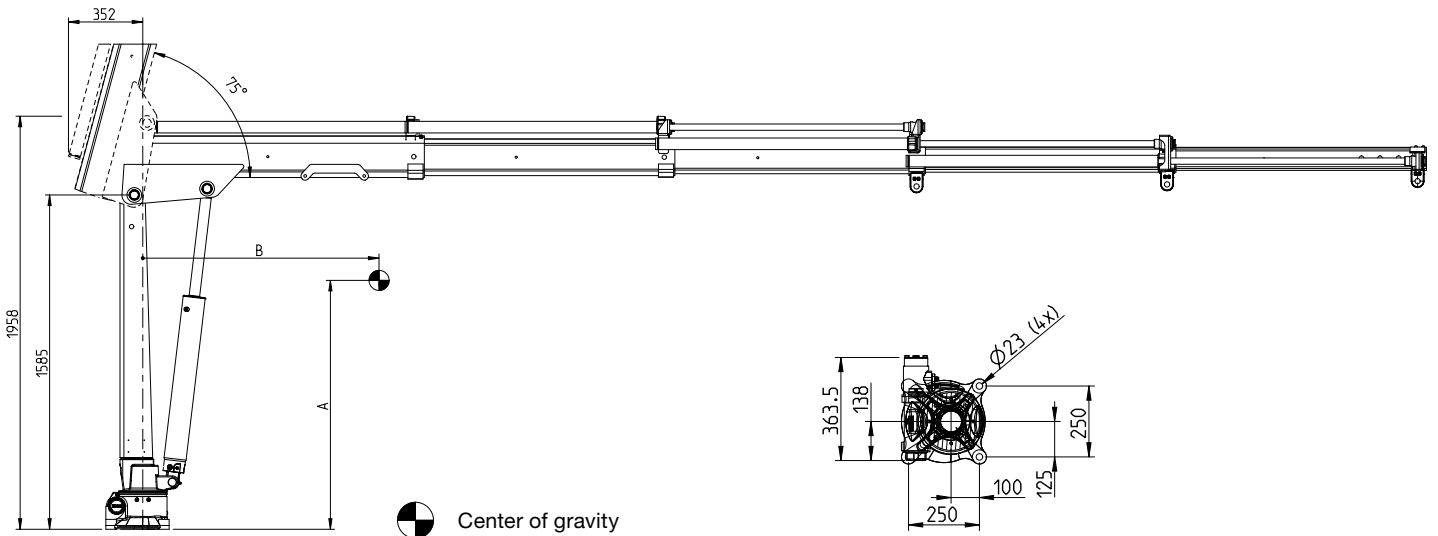

 Center of gravity

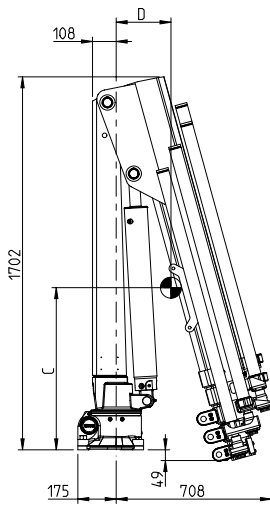

A	B	C	D
1180	1120	740	250

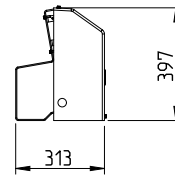
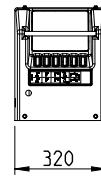

Capacity plate HIAB T-DUO 038-3

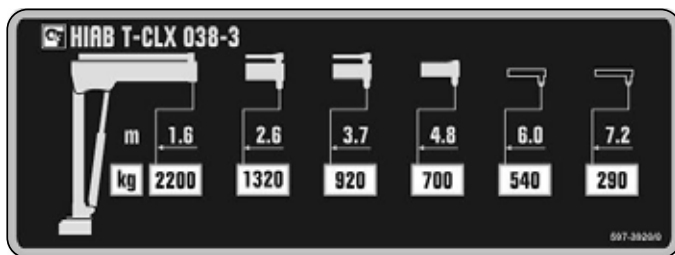

Load diagram HIAB T-DUO 038-3

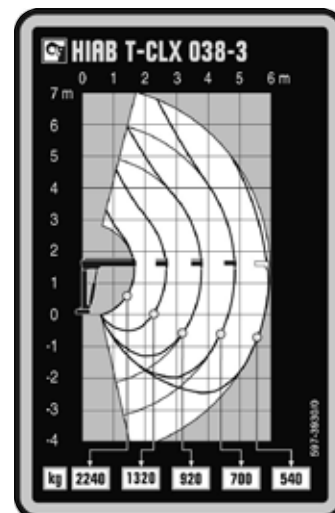

HIAB T-DUO 038-4

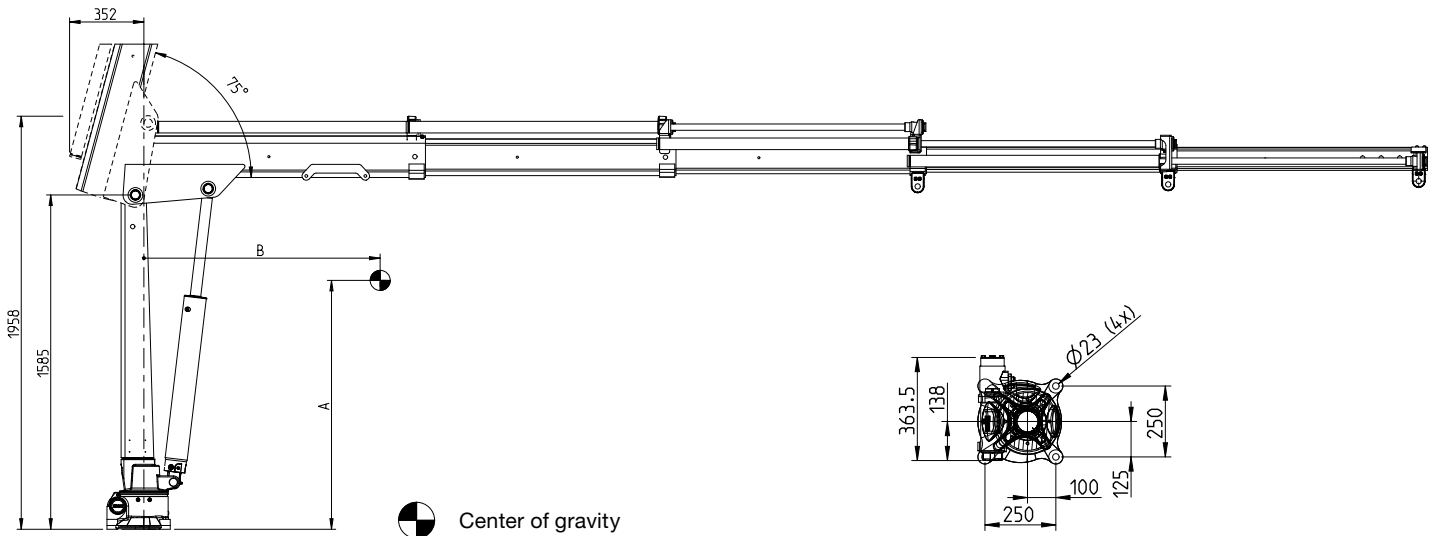

Center of gravity

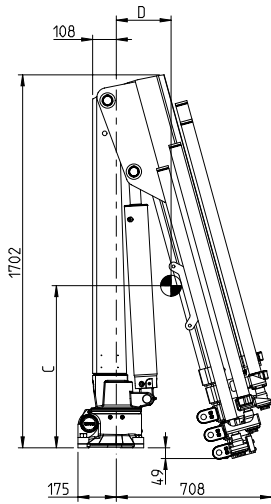

A	B	C	D
1240	1520	760	280

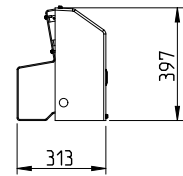
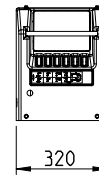

Capacity plate HIAB T-DUO 038-4

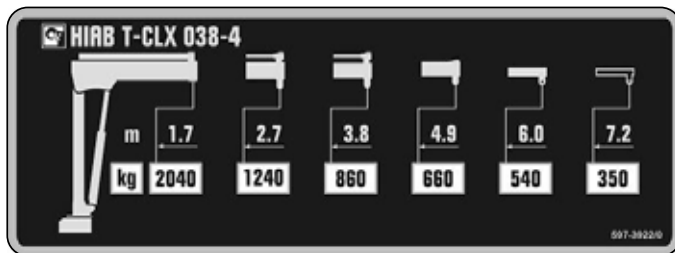

Load diagram HIAB T-DUO 038-4

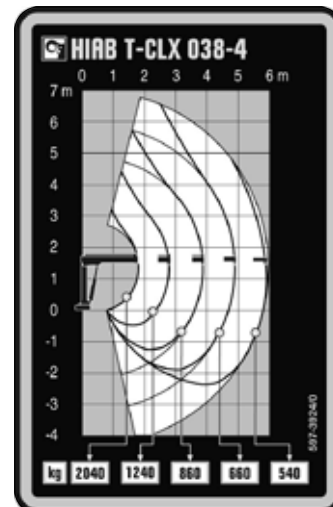

HIAB T-DUO 038

FIXED STABILIZER

HYDRAULIC LEG

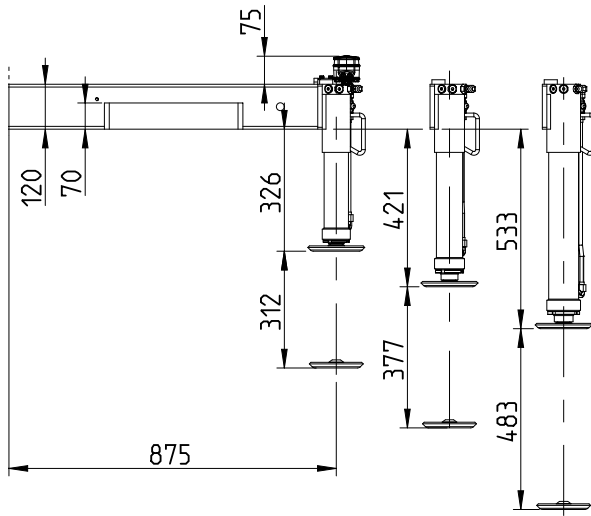

FIXED STABILIZER WITH
TILTING DEVICE

HYDRAULIC LEG

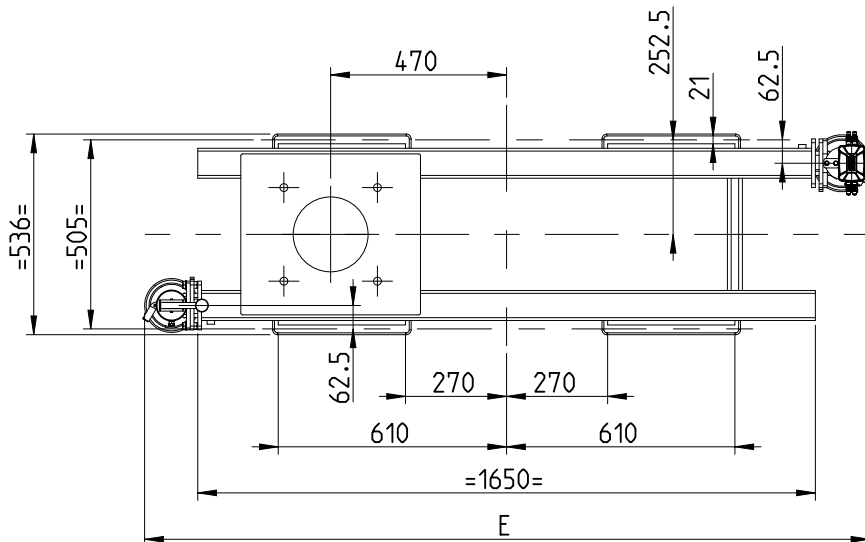
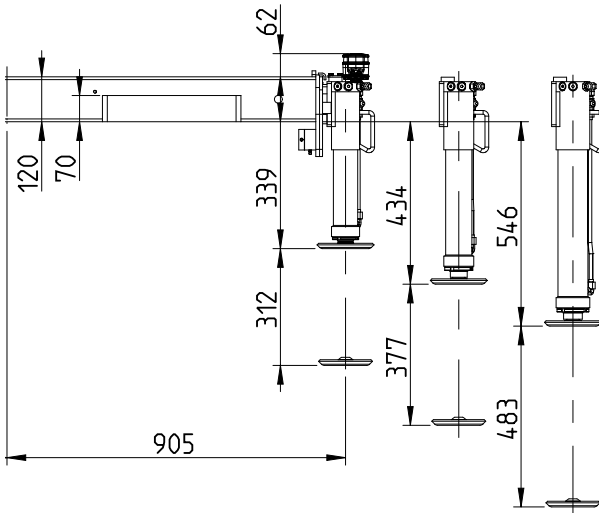

	E
Fixed	1826
Fixed with tilting device	1886
Extension	1866
Extension with tilting device	1926

HIAB T-DUO 038

EXTENSION STABILIZER

HYDRAULIC LEG

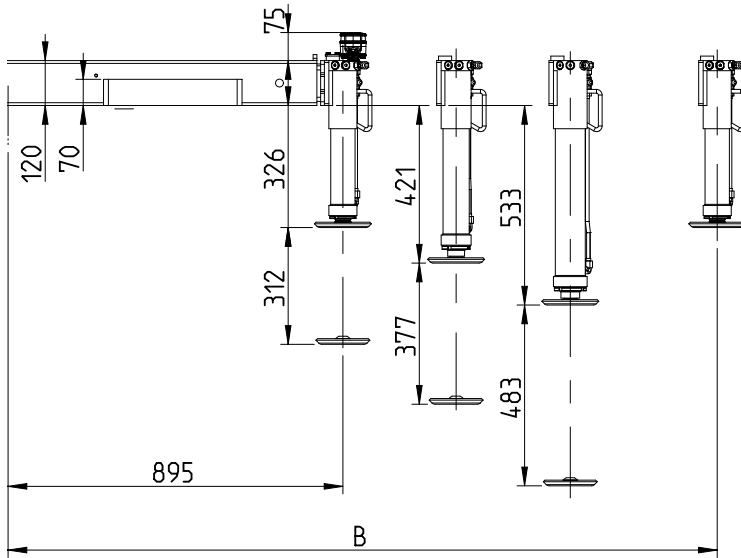

FIXED STABILIZER WITH TILTING DEVICE

HYDRAULIC LEG

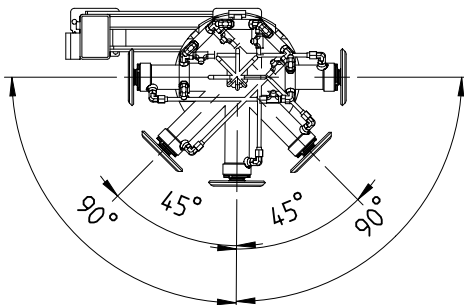
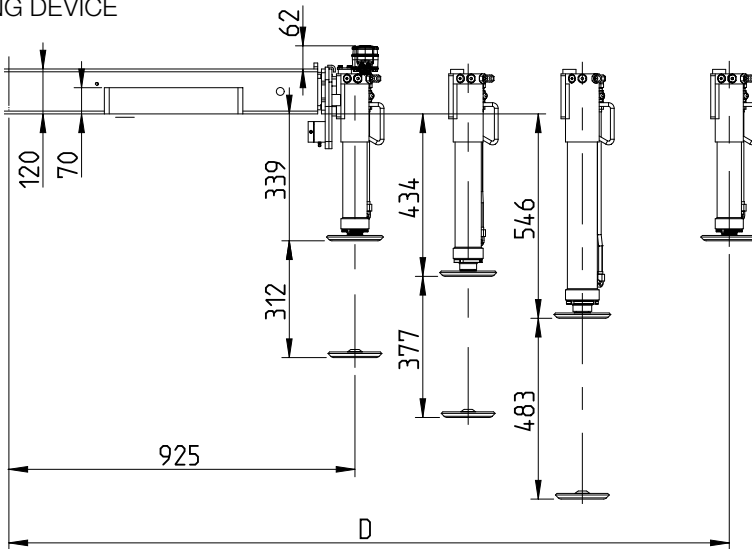

STABILIZER WITH TILTING DEVICE
PARKING POSITION

	A	B	C	D
300/300	1195	1195	1225	1225
800/800	1695	1195	1725	1225

BUILT TO PERFORM

Hiab is the world's leading provider of on-road load handling equipment. Customer satisfaction is the first priority for us. Hiab's product range includes HIAB loader cranes, JONSERED recycling and forestry cranes, LOGLIFT forestry cranes, MOFFETT truck mounted forklifts and MULTILIFT demountables, as well as DEL, WALTCO and ZEPRO tail lifts.

hiab.com

Hiab is part of Cargotec.

cargotec.com

Disclaimer. We reserve the right to make changes. Illustrations, drawings and data are not always in accordance with the latest version or standard model in production. The models in the pictures may present special equipment or colours.

TD-TDU0008-EN-EU_150606